



10KW Portable EV Charger

SET450-20B

User manual

SAVE THESE INSTRUCTIONS

This manual contains important instructions for 10KW portable charger that shall be followed during installation, operation and maintenance of the unit.



WARNING ELECTRICAL

THIS EQUIPMENT SHOULD BE INSTALLED, ADJUSTED, AND SERVICED BY QUALIFIED ELECTRICAL PERSONNEL FAMILIAR WITH THE CONSTRUCTION AND OPERATION OF THIS TYPE OF EQUIPMENT AND THE HAZARDS INVOLVED. FAILURE TO OBSERVE THIS PRECAUTION COULD RESULT IN DEATH OR SEVERE INJURY.

READ THIS MANUAL THOROUGHLY PRIOR TO INSTALLATION AND ENERGIZING THE EQUIPMENT. INSPECTION AND MAINTENANCE OF THIS EQUIPMENT SHOULD BE PERFORMED IN ACCORDANCE WITH THE OPERATING PROCEDURES DETAILED IN THIS MANUAL.

THE PURPOSE OF THIS MANUAL IS TO PROVIDE YOU WITH INFORMATION NECESSARY TO SAFELY OPERATE, MAINTAIN, AND TROUBLESHOOT THIS EQUIPMENT. KEEP THIS MANUAL FOR FUTURE REFERENCE.

DO NOT USE THIS PRODUCT IF THE EV CABLE IS FRAYED, HAS DAMAGED INSULATION OR ANY OTHER SIGN OF DAMAGE.

DO NOT USE THIS PRODUCT IF THE ENCLOSURE OR THE EV CONNECTOR IS BROKEN, CRACKED, OPEN, OR SHOW ANY OTHER INDICATION OF DAMAGE. INTENDED FOR USE WITH PLUG-IN ELECTRIC VEHICLES ONLY.

PREMISE VENTILATION NOT REQUIRED.

THE INFORMATION CONTAINED IN THIS MANUAL IS SUBJECT TO CHANGE WITHOUT NOTICE.

Contents

1.1 Overview.....	4
1.2 Main parts.....	4
1.3 Specification.....	4
1.4 Features.....	5
2. Operation.....	6
2.1 Connection.....	6
2.1.1 AC input wire connection.....	7
2.2 Charger Start-up Procedure.....	7
2.2.1 preparation.....	7
2.2.2 Panel Indicator status.....	8
2.4 Charging Operation Procedure.....	8
2.5 Charger interface.....	9

1.System overview

1.1 Overview

10KW portable Charger converts a 220Vac/380Vac voltage into DC voltage to directly charge an electric vehicle's lithium ion battery. In addition, the charger utilizes a CHAdeMO compliant communications protocol and power connector.

No matter where you go, how far it is, you can charge it anytime. Due to the light and small size, it can be put into your car charging interface.



Figure 1. SET450-20BX Appearance

1.2 Main parts

No	Name	Model	Instructions	Qty
1	Monitor	SET1410	Intelligent Control Center	1
2	Power module		AC/DC	1
3	Metering unit			1
4	AC input		Input MCB	1
5	DC output		MCB/Relay/Diode	1
6	DC connector		Chademo/Combo2	1

1.3 Specification

	Item	Rating and Property	Remark
	Efficiency @ full load	≥93%	

Shenzhen SETEC POWER Co.,Ltd

System Index	OHZ~20MHz clutter VP-P	0.20%	
	Insulation strength(V)	2000VAC/50Hz	10mA, 1min No flashover
	Insulation resistance (MΩ)	10	Ground
	Power Surge	No	Soft start
	Module load indication	LED display output DC current LED10 class	LED10 Class, +3LED
	Output current display accuracy	≤±10%	
Environmental indicators	Ambient temperature	-25℃~50℃	Storage: -40° C to 70 ° C
	environment humidity	≤90% (40±2 ° C)	Storage: 95% (40 ± 2 ° C)
	Altitude	1500m	Above 1500m, derate.
	Electromagnetic Compatibility	EN55022 CLASS A	(YD/T983-1998)A Class
Input	Line voltage (VAC)	380/220	300-500V/175-300V
	Type of voltage	AC three-phase Five-wire / single-phase	
	frequency (HZ)	45~55	
	Power Factor	0.99	
	Current THD	≤5%	
	Input undervoltage protection value (V)	305±15V	
Output	Nominal output voltage (V)	387V	
	Output current (A)	0~20A	
	Regulation accuracy	≤0.5%	
	current accuracy	≤1%	
	Peak to peak ripple coefficient	≤0.5%	
	Output voltage range (V)	200~450V	
	Max Output Power	10kW	
Mechanical	Packing	Wooden & cartoon	
	Size (W×H×D)	54*44*28	cm
	Gross Weight	30Kg	With 1 connector
	IP	IP21	
Other	Cooling	Forced cooling	Controlled by Load and temperature

1.4 Features

SET450-20BX is portable charger with high voltage and small current. Inner charging module is with high-efficiency, high-frequency, full-bridge three-level soft-switch technology and digital control. Equipment monitoring module is with high intelligence,

improved functions, available interface.

- Max 10KW, output current limited 20A;
- Adopting intelligent charging module, module built-in CPU to realize CPU intelligent management, with manual / automatic dual control function.
- Adopting intelligent module, to be a distributed control system, a single module failure does not affect whole system operation
- Charging module adopt ZVZCS and three-level soft-switching technology, efficiency up to 95%
- Charging module adopt a unique full isolation dust structure, built-in cooling fan adopt intelligent speed control, and can automatically adjust the fan speed according to the load situation, to extend the life of the fan.
- Charging module comes with APFC function, power factor more than 0.99, the rate of total harmonic current distortion THD <5%.

2. Operation

2.1 Connection

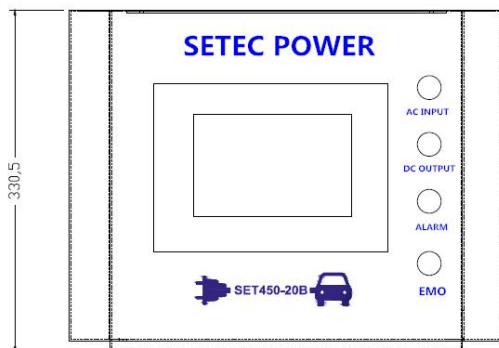


Figure 1 Outside View

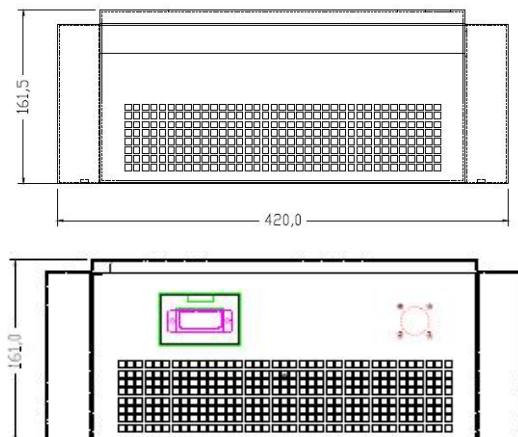


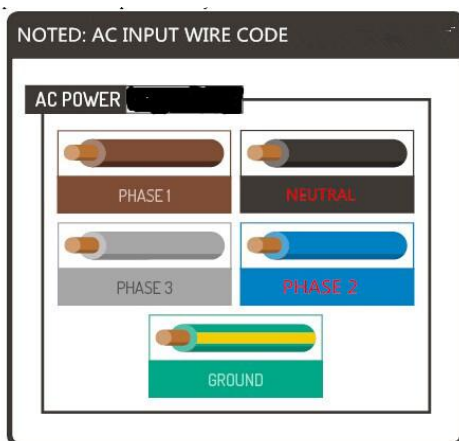
Figure 2. Rear View



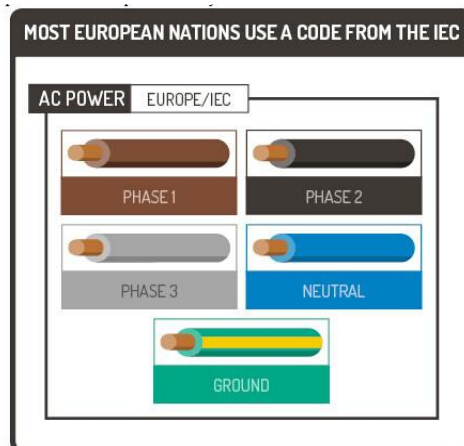


Figure 3. AC input/ Signal output/ DC output connectors

2.1.1 AC input wire connection



CHINESE MARKET



EUROPEAN NATIONS



A:Brown
B:Gray
C: Blue
N: Black
PE:Yellow-Green

input wire. You will find there is a neutral wires.

After installation, do first comprehensive inspection. Including:

1. whether the screws loose wiring enclosure;
2. AC input connection correct ;
3. charger and charging pile communication cable is connected properly;

4. AC input circuit breaker is in the OFF state

5. Emergency button is in the OFF status

Noted: Use this button to shut down the device in an emergency situation. Pressing the EMO will shunt trip the internal breaker and stop charging.

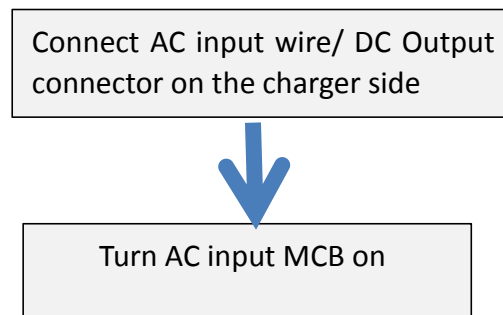
2.2.2 Panel Indicator status

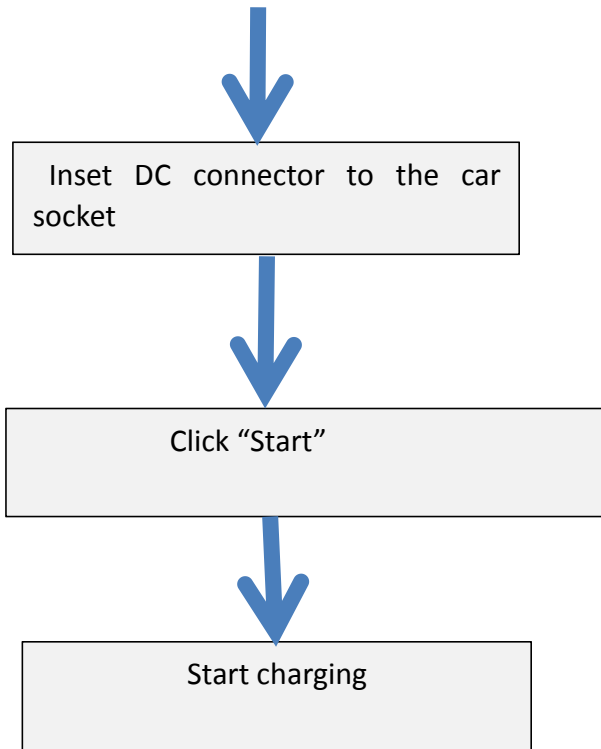
Before charging operation, you must confirm that it conforms to the following indicators:

Indicators	Status before charging
Output	Off
Input	On
Alarm	Off

Pls do not charge it if it is not conform as described above the indicator status.

2.4 Charging Operation Procedure





2.5 Charger interface



Noted: if you order 2 connectors(chademo & ccs), when you charging, you should choose one accrdingly.

Click chademo, and then start, it will start charging.